

frame size order sheet

name of the customer _____

date _____

step 1: measure customer's body

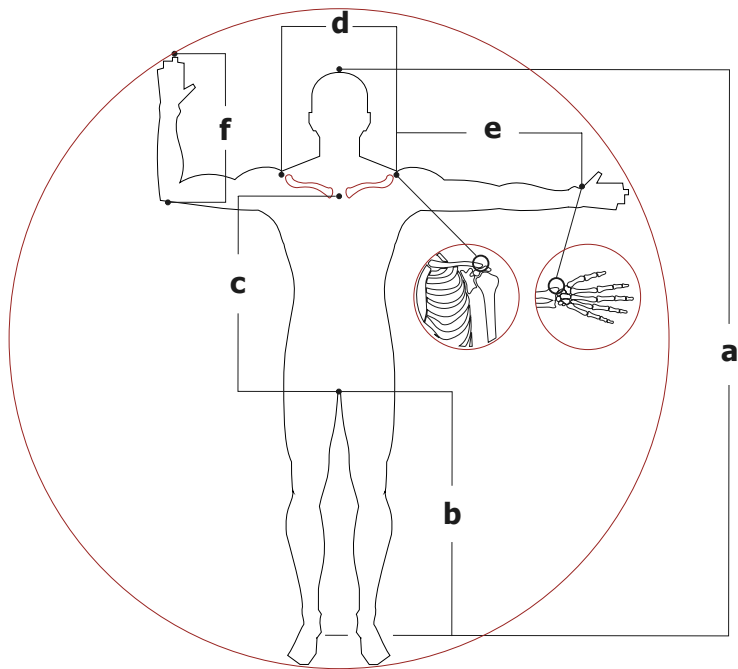

(a) body height

(b) inseam

(c) torso

(d) shoulder width

(e) arm

(f) elbow to finger tip

(g) body weight

additional note _____

step 2: position data or framesize

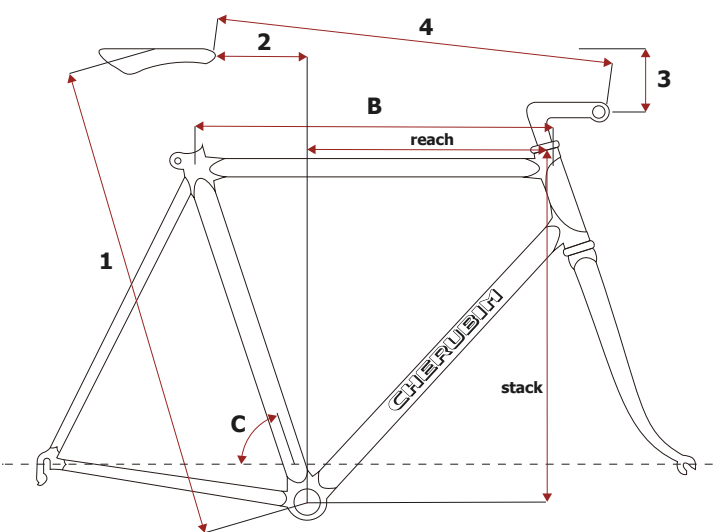

(1) saddle height

(2) saddle seatback

(specify saddle length)

(3) saddle to handlebar drop

(4) saddle to handlebar distance

(specify saddle length)

(B) top tube length (effective)

stack

(C) seat tube angle

reach

If you have a previous bike fitting or position datas please send it to Cherubim.